

POINTING MORTAR

CALCIUM SILICATE TILE UNIT,
HI-BOND MASONRY VENEER MORTAR -
POLYMER FORTIFIED,
LATICRETE AIR & WATER BARRIER,
CEMENT BOARD,
EXTERIOR SHEATHING,
STEEL STUD WALL,
BATT INSULATION (THICKNESS
DEPENDENT ON REQUIRED R-VALUE),
VAPOR BARRIER (LOCATION
DEPENDENT ON CLIMATE ZONE),
GYPSUM WALLBOARD

COMPRESSIBLE BACKER
ROD AND SEALANT

RAKE BACK MORTAR BETWEEN
UNITS APPROX. 3/4" DEEP.
COVER w/ BACKER ROD AND
SEALANT TO PROTECT MORTAR

BULLNOSE CALCIUM SILICATE
WATERTABLE UNIT
1" MIN

MASONRY TIE OR MECHANICAL
ANCHOR IN HEAD JOINT

VENT @ 24" o.c.

INSULATION RETAINER

ADJUSTABLE WALL TIE

CALCIUM SILICATE MASONRY UNIT,
MIN. 1" AIR SPACE,
RIGID INSULATION (THICKNESS
DEPENDENT ON REQUIRED R-VALUE),
LATICRETE AIR & WATER BARRIER,
EXTERIOR SHEATHING,
STEEL STUD WALL,
BATT INSULATION (THICKNESS
DEPENDENT ON REQUIRED R-VALUE),
VAPOR BARRIER (LOCATION
DEPENDENT ON CLIMATE ZONE),
GYPSUM WALLBOARD

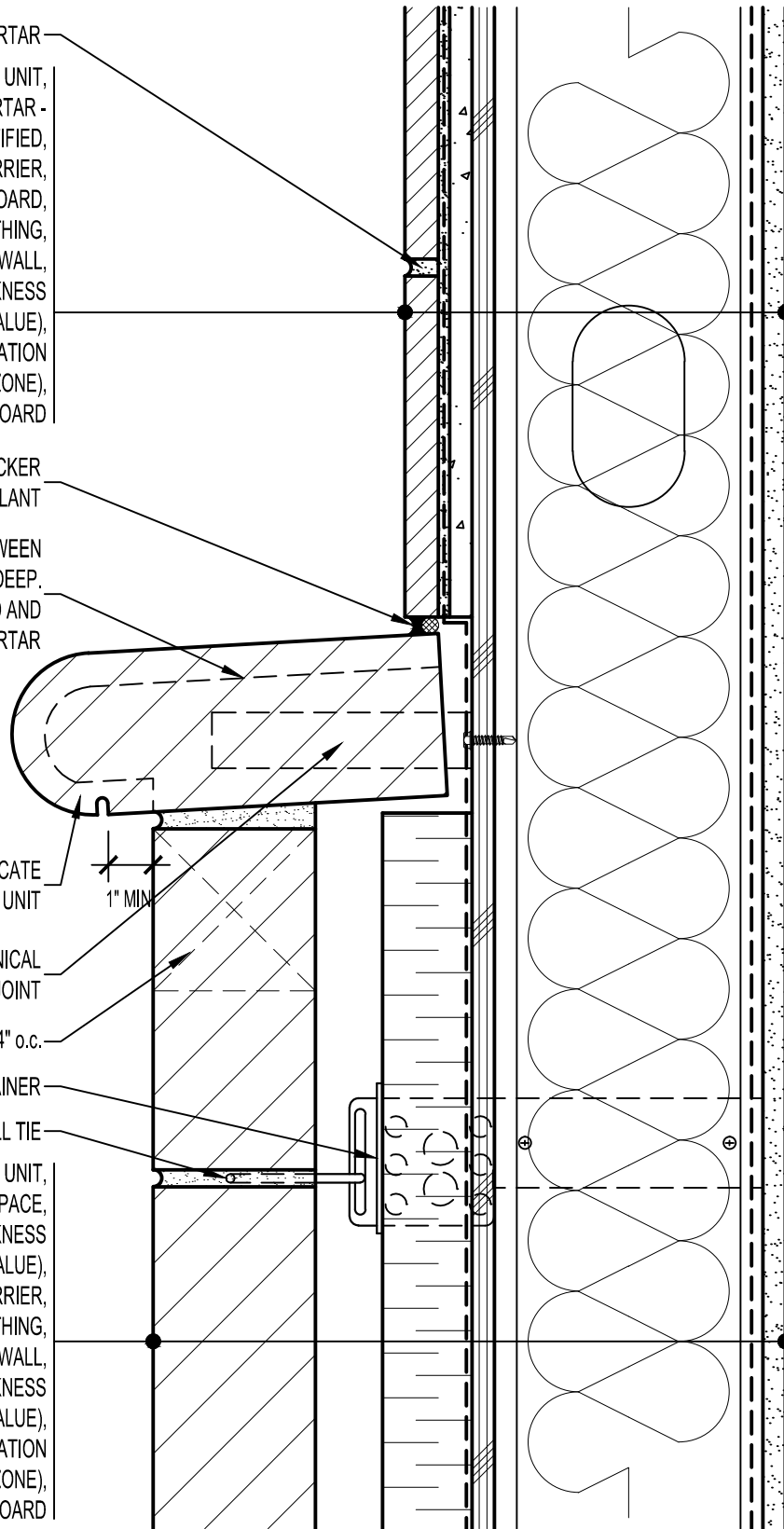

Arriscraft 

Building Stone · Brick · Limestone

ARRISCRAFT-CADD

DETAIL No:

SS08SAT

TITLE: FULL-BED / THIN ADHERED
CALCIUM SILICATE TRANSITION
(BULLNOSE WATERTABLE)

U106

DATE DRAWN:
03/02/15

SCALE:
3"=1'-0"

DRAWN BY:
TRI