

Prestige
STONE PRODUCTS  **LLC.**



Where quality craftsmanship
is a way of life...[©]

CRAFTSMANSHIP

in every detail

Table of Contents



6-11	Commercial and Residential Applications	40-43	Southern Limestone
12-19	Weatherledge	44-45	Salvaged Wood Stone
20-25	Old County Ledge	46-47	Fieldstone
26-29	Pro Stack	48-49	Thin Veneer Brick
30-33	Ledgestone	50-57	Accessory Guide
34-37	Quarry Cut	58	Installation Guide
38-39	Dressed Ashlar	59	Warranty

Manufactured Stone Veneer

VS Natural Quarried Stone Veneer

- Not weight bearing, no need for a footer or additional reinforcement and expansion joints
- Competitively priced to be well within budget constraints
- Much larger variety of colors and shapes



Bordeaux Creek
OLD COUNTY LEDGE



Portland Mist
OLD COUNTY LEDGE



Featured Commercial Applications



Cumberland Fog Pro Stack



Portland Mist Weatherledge



Monterey Weatherledge



Portland Smoke Old County Ledge

Featured Residential Applications



Featured Residential Applications



Weatherledge

KODIAK RIDGE

- The Weatherledge series is an attractive interweaving of stone that will make your next venture stand out.
- Eye-catchingly honed, its style is not as rugged or complex. It is characterized by smoother edges and rectangular pieces that draw you in to its allure.



Bordeaux Creek
WEATHERLEDGE



Kodiak Ridge
WEATHERLEDGE



Buck Country
WEATHERLEDGE



Weatherledge

BLUEGRASS



Imperial
WEATHERLEDGE



Portland Dusk
WEATHERLEDGE



Portland Mist
WEATHERLEDGE



Bluegrass
WEATHERLEDGE



Blanc
WEATHERLEDGE



- Weatherledge ranges from 1½ inches to 6 inches tall, and 4 inches to 23½ inches long.

Weatherledge

CHARCOAL



Charcoal
WEATHERLEDGE



Sequoia
WEATHERLEDGE



Portland Smoke
WEATHERLEDGE



Monterey
WEATHERLEDGE



Weatherledge

HARVEST



Tan
WEATHERLEDGE



Harvest
WEATHERLEDGE



Desert Hollow
WEATHERLEDGE



Old County Ledge

PORTLAND SMOKE

- With smooth faces and a modern, angular edge, Old County Ledge is the stone of choice for those seeking an orderly look.
- This series is a well-organized combination of varied sizes and texture, but with an undeviating line.



Kodiak Ridge
OLD COUNTY LEDGE



Portland Smoke
OLD COUNTY LEDGE



Blanc
OLD COUNTY LEDGE



Old County Ledge

PORTLAND MIST



Sante Fe
OLD COUNTY LEDGE



Bluegrass
OLD COUNTY LEDGE



Moonlit Forest
OLD COUNTY LEDGE



Portland Mist
OLD COUNTY LEDGE



Portland Dusk
OLD COUNTY LEDGE



- Old County Ledge ranges in size from 1½ inches to 7 inches tall, by 4 inches to 23½ inches long.

Old County Ledge

BUCK COUNTRY



Bordeaux Creek
OLD COUNTY LEDGE



Buck Country
OLD COUNTY LEDGE



Harvest
OLD COUNTY LEDGE



Charcoal
OLD COUNTY LEDGE



Pro Stack

IMPERIAL

- With a modern look that contains clean and contemporary lines, our ProStack brings you the most current style. The panels are uncluttered, long, and straight-edged.
- Simple yet dynamic, this choice of stone gives you the orderly, unfettered look you've been seeking.



Mesa Cream
PRO STACK



Imperial
PRO STACK



Charcoal
PRO STACK



White Onyx
PRO STACK



Portland Smoke
PRO STACK



Pro Stack

PORTLAND MIST



Moonlit Forest
PRO STACK



Buck Country
PRO STACK



Cumberland Fog
PRO STACK



Black Onyx
PRO STACK



Portland Mist
PRO STACK



Natural
PRO STACK



• Pro Stack panels are 3 inches tall, 6 to 23½ inches long, and 1 inch deep.

Ledgestone

CHARCOAL

- The Ledgestone series lends abundant character to any project. Rustic with varying depths, the texture is an appealing mix that pleases the eye. Jagged and tapered pieces abound, grasping the essence of the natural ledgestone we mold.



Kodiak Ridge
LEDGESTONE



Monterey
LEDGESTONE



Buck Country
LEDGESTONE



Charcoal
LEDGESTONE



Ledgestone

SANTA FE



Bluegrass
LEDGESTONE

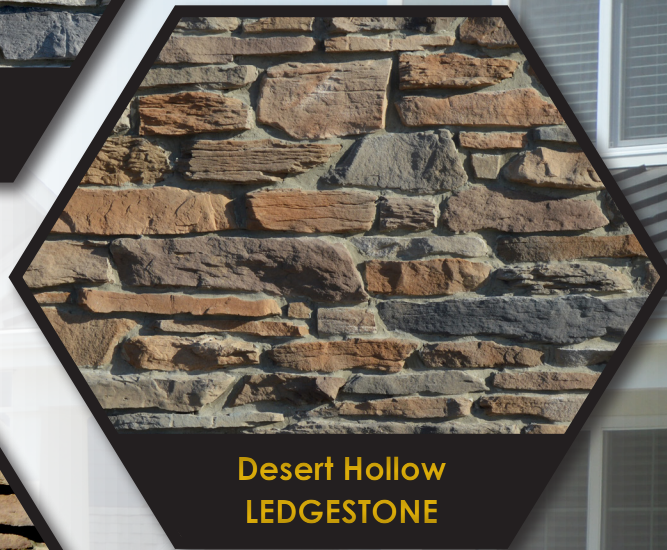

Desert Hollow
LEDGESTONE



Harvest
LEDGESTONE



Santa Fe
LEDGESTONE



• Ledgestone ranges from 1½ inches to 6 inches tall, and 4 inches to 23½ inches long.

Quarry Cut

PORTLAND SMOKE

- With a stylish and edgy feel, Quarry Cut fits the bill when you want a well-arranged look.
- Chic and cultivated with its stack ledge and smaller thin pieces, it brings you uniform lines and diverse color. Perfect for a distinct look to set your design apart.



Buck Country
QUARRY CUT



Portland Smoke
QUARRY CUT



Charcoal
QUARRY CUT



Portland Mist
QUARRY CUT

Quarry Cut

KODIAK RIDGE



Bluegrass
QUARRY CUT



Moonlit Forest
QUARRY CUT



Kodiak Ridge
QUARRY CUT



- Quarry Cut ranges from 1 inch to 4½ inches tall, and 3 inches to 23½ inches long.

Dressed Ashlar

BRAEMAR

- Dressed Ashlar's straight lines and squared edges will give your next project a strong consistency that exudes culture and refinement.
- Dressed Ashlar ranges from 3 inches to 10 inches tall, and 6 inches to 15 inches long.



Braemar
DRESSED ASHLAR



Wexford
DRESSED ASHLAR



White Onyx
DRESSED ASHLAR



Southern Limestone

BRAEMAR

- Southern Limestone's traditional look gives projects a bold and strong appearance. They are a more natural cut, making it the perfect addition.



Smokey
SOUTHERN LIMESTONE



Wexford
SOUTHERN LIMESTONE



Ohio
SOUTHERN LIMESTONE



White Onyx
SOUTHERN LIMESTONE



Braemar
SOUTHERN LIMESTONE

Southern Limestone

BURNT RUSSET



Aspen
SOUTHERN LIMESTONE



Jackson Creek
SOUTHERN LIMESTONE



Portland Mist
SOUTHERN LIMESTONE



Charcoal
SOUTHERN LIMESTONE



Burnt Russet
SOUTHERN LIMESTONE



• Southern Limestone is approximately 2½ inches to 16 inches tall, by 5 inches and up to 23½ inches long.

Salvaged Wood Stone

NATURAL



Natural
SALVAGED WOOD STONE



Farmhouse
SALVAGED WOOD STONE

- Minutely detailed, Salvaged Wood Stone brings a fresh line to your space with its weathered details. The striking reclaimed texture of this stone will give your project the finish that it deserves.
- Salvaged Wood Stone has the following included in the box: (Not sold by the individual piece)
3- 8.5"x 32", 3- 7"x 32", 1- 8.5"x 20", 1- 8.5"x12", 1- 7"x 20", 1- 7"x 12"



Fieldstone

PORTLAND SMOKE

- Choosing a homey look with stone brings an exciting blend of variables to choose from. Our Fieldstone clarifies this style and brings it to the forefront. With a varied and irregular woodsy union of shapes, this series is a warm invitation to come home and unwind.
- Fieldstone ranges from 4 inches to approximately 22 inches.



Bluegrass
FIELDSTONE



Tan
FIELDSTONE



Charcoal
FIELDSTONE



Portland Smoke
FIELDSTONE



Kodiak Ridge
FIELDSTONE



Buck Country
FIELDSTONE

Thin Veneer Brick

FARMHOUSE

- Thin Veneer Brick is a throwback to when brick was hand-made and unique. For a rustic flair, our brick is perfect on your next project!
- Thin Veneer Brick is 2½ inches wide by 8 inches long by 1 inch deep.

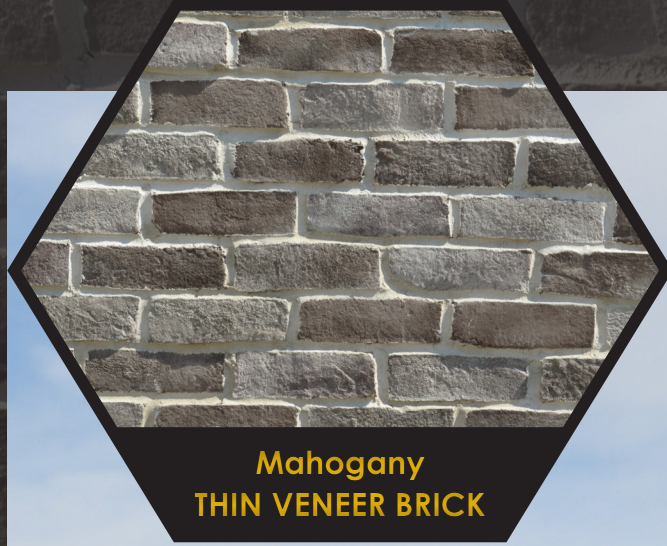

Mahogany
THIN VENEER BRICK

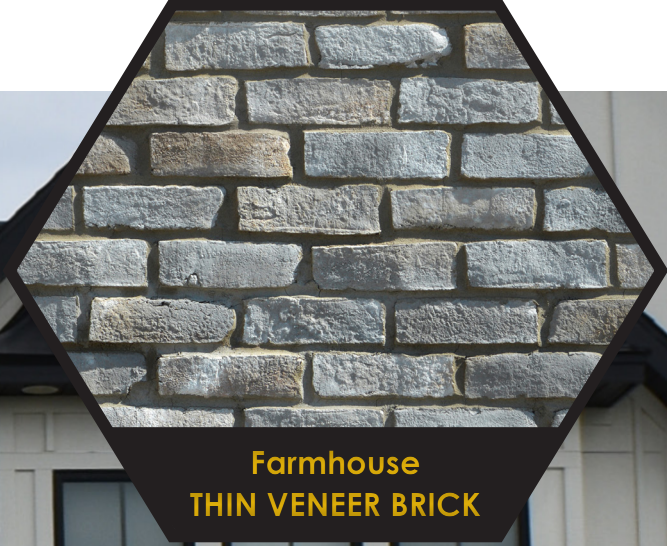

Farmhouse
THIN VENEER BRICK



Imperial
THIN VENEER BRICK



White Onyx
THIN VENEER BRICK



Redwood
THIN VENEER BRICK



Black Onyx
THIN VENEER BRICK

Accessory Sizing Guide

HEARTHSTONE

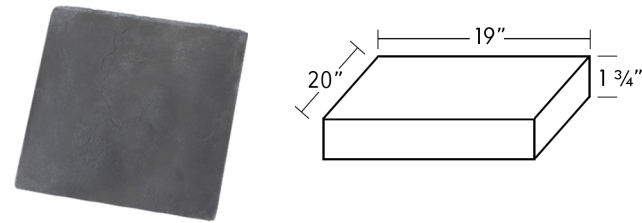

WATERTABLE SILL

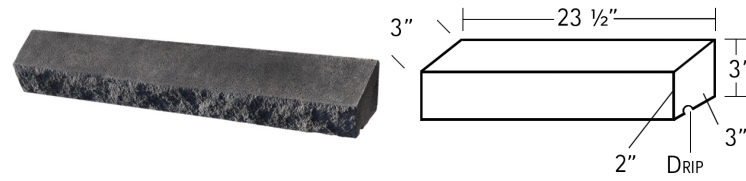

WALL CAP

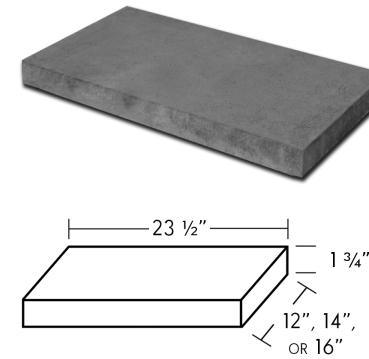

PIER CAP

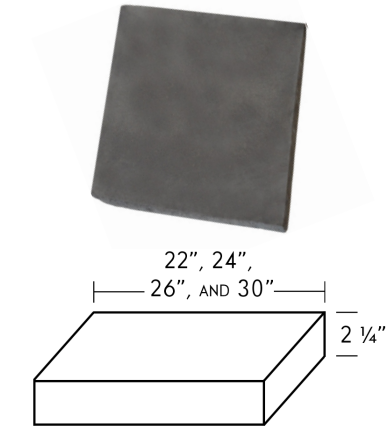

WINDOW TRIM

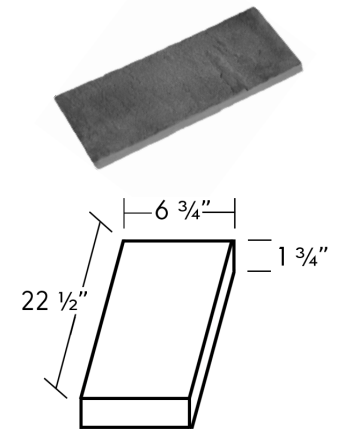

RECEPTACLE BLOCK

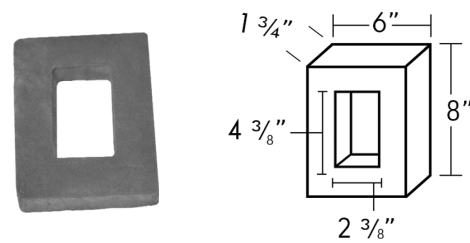

HYDRANT BLOCK

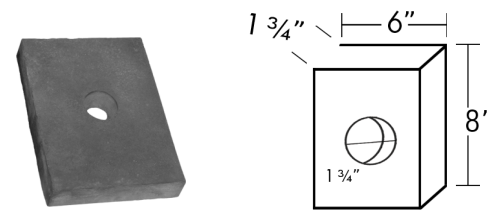

ROCKFACE KEYSTONE

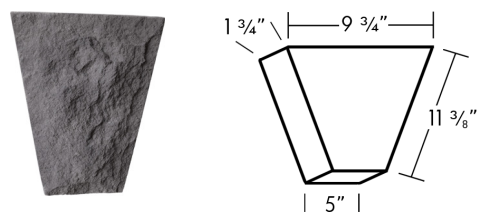

LIGHT BLOCK

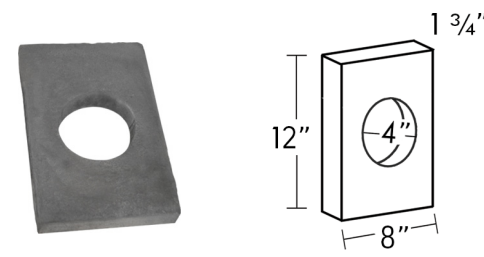

ROWLOCK

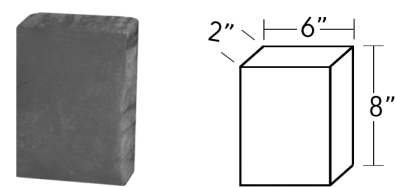

AVAILABLE COLORS



















AVAILABLE COLORS



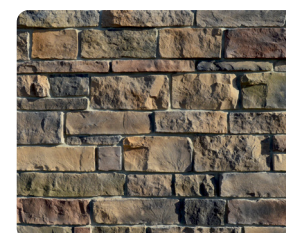















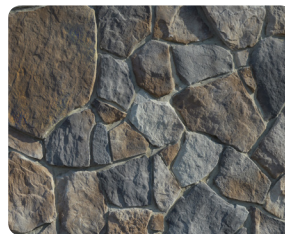





Imperial Pro Stack with white Rowlocks and Water Table Sills

Accessory Color Reference Guide

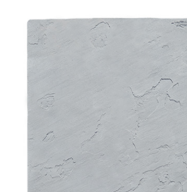
	WEATHERLEDGE	LEDGESTONE	OLD COUNTY LEDGE	PRO STACK
BLUEGRASS				
BUCK COUNTRY				
CHARCOAL				
KODIAK RIDGE				
PORTLAND SMOKE				
TAN				

All colors listed here are for suggestion only and are solely at the discretion of the user.

FIELDSTONE	SOUTHERN LIMESTONE	QUARRY CUT	SUGGESTED COLORS	
				
				
				
				
				
				

For color, please reference stone samples or current installations for color representation.

Accessory Color Reference Guide

	PRO STACK	PRO STACK	QUARRY CUT	OLD COUNTY LEDGE
PORTLAND MIST				
MOONLIT FOREST				
NATURAL				
PORTLAND DUSK				
BLACK ONYX				
IMPERIAL		WHITE ONYX 		

All colors listed here are for suggestion only and are solely at the discretion of the user.

	WEATHERLEDGE	SOUTHERN LIMESTONE	SUGGESTED COLORS
PORTLAND MIST			Tan Gray
BURNT RUSSET			Brown Charcoal
SEQUOIA			Tan Gray Brown
PORTLAND SMOKE / SMOKEY			Gray Charcoal
JACKSON CREEK			Brown Charcoal
IMPERIAL		WHITE ONYX 	White

For color, please reference stone samples or current installations for color representation.

Accessory Color Reference Guide

	WEATHERLEDGE	LEDGESTONE	OLD COUNTY LEDGE	SUGGESTED COLORS	
BLANC					
BORDEAUX CREEK					
DESERT HOLLOW					
HARVEST					
MONTEREY					
SANTA FE					

All colors listed here are for suggestion only and are solely at the discretion of the user.

	PRO STACK	SUGGESTED COLORS	
CUMBERLAND FOG			
MESA CREAM			
ASPEN			
BRAEMAR			
OHIO WHITE VEIN			
WEXFORD			

For color, please reference stone samples or current installations for color representation.

1. INSTALLATION OVER WOOD FRAMING

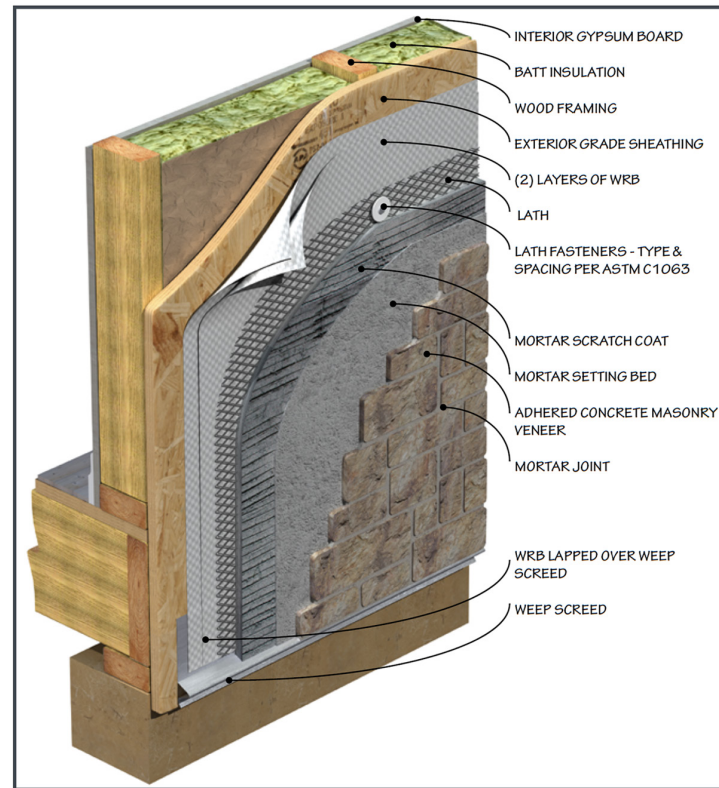

2. INSTALLATION OVER CONCRETE MASONRY UNITS

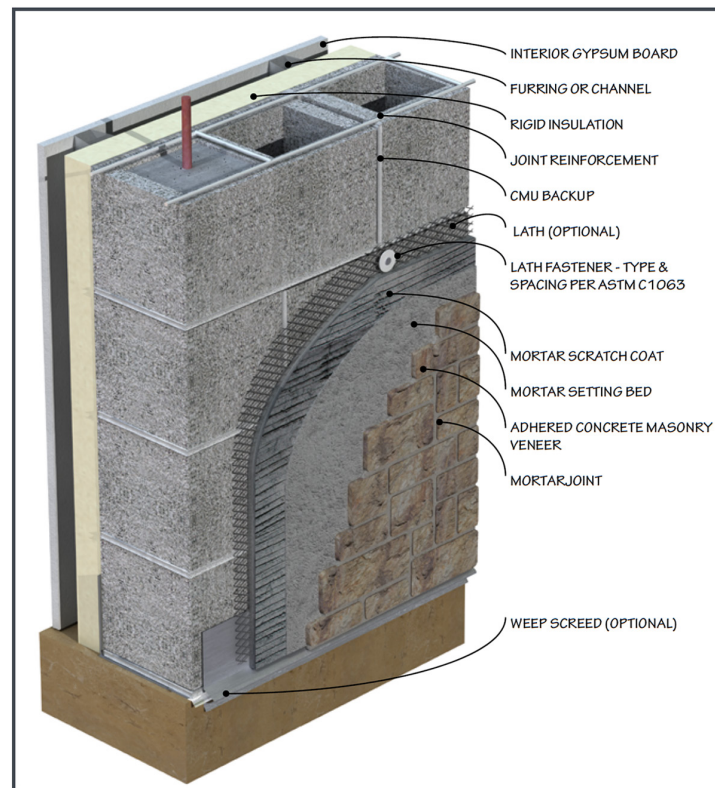

APPLYING THE METAL LATH

Apply a moisture barrier of housewrap and 30 pound felt. Overlap horizontal joints 5 inches and vertical joints 8 inches. All corners must be wrapped a minimum of 16 inches. Then apply 2.5 pound metal lath or equivalent. Metal lath must be overlapped in the same manner as the felt. Fasten with wide crown staples at least 1 inch in length. Make sure all chimneys and windows are properly flashed.

APPLYING THE SCRATCH COAT

Apply a scratch coat using Type M or Type N mortar, approximately 1/4 inch to 1/2 inch thick. Make sure the mortar is not too wet or too dry.

APPLYING THE STONE

Install corners first. Spread mortar evenly on the back of the stone, approximately 1/2 inch thick. When applying the stone to the wall, move the stone back and forth a little bit in a circular motion. Make sure your mortar is not too dry or too wet for proper bonding. In hot weather you may need to wet down the back of the stone or the scratch coat.

GROUTING INSTRUCTIONS

Use a grout bag to grout the joints, making sure you do not get cement on the face of the stone. Let the grout joint set up until it is slightly dry, then strike the joint with a jointer or other similar implement. Make sure it isn't too wet or too dry. If the mortar wets or stains a brush it is too wet. Brush out the joints with a soft brush.

- 50 year Limited Warranty from the date of purchase, when installed to Manufacturer's instructions and according to local building codes. Warranty does not cover damaged product resulting from building settlement, wall movement, improper installation, or discoloration due to airborne contaminants.
- The Contractor and Architect are responsible for proper installation. Prestige Stone Products, LLC is not responsible for the structural wall surface it is applied to. Make sure to follow all of your local building codes. Building codes will vary from state to state, county to county.
- Warranty is subject to all other terms of the written warranty, a copy of which can be obtained from your dealer or by visiting:

www.prestigestoneproducts.com

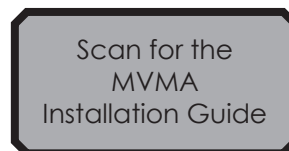



9290 Winesburg Road
Dundee, OH 44624
www.prestigestoneproducts.com
330.439.5318

